

**FEMALE RIGHT ANGLE PLUG SOLDER TYPE**

**R222.152.000**

**CABLE .085**

Series : SMP

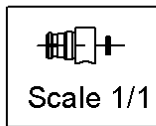
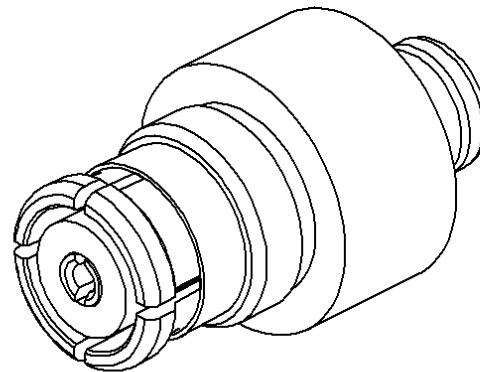
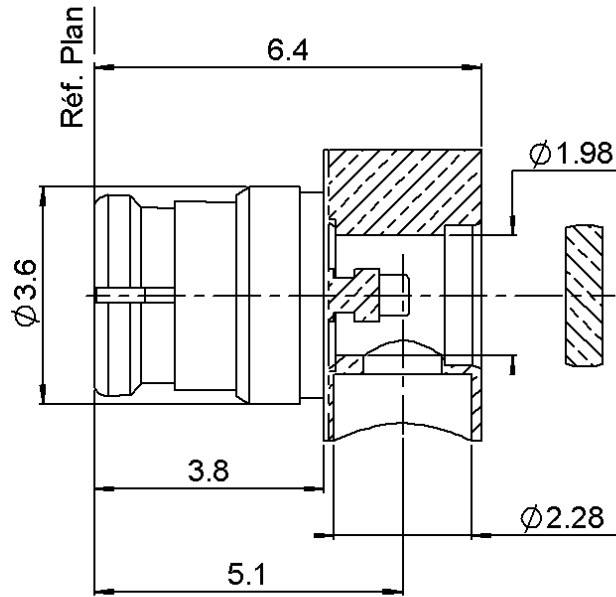

All dimensions are in mm.



COMPONENTS	MATERIALS	PLATINGS (µm)
BODY	BERYLLIUM COPPER	GOLD 1.3 OVER NICKEL 2
CENTER CONTACT	BERYLLIUM COPPER	GOLD 1.27 OVER NICKEL 1.27
OUTER CONTACT	-	-
INSULATOR	PTFE	-
GASKET	-	-
OTHERS PARTS	BERYLLIUM COPPER,BRASS	GOLD 1.3 OVER NICKEL 2
-	-	-
-	-	-

Issue : 0606 C

In the effort to improve our products, we reserve the right to make changes judged to be necessary.



**FEMALE RIGHT ANGLE PLUG SOLDER TYPE**

**R222.152.000**

**CABLE .085**

Series : SMP

**PACKAGING**

Standard	Unit	Other
<b>100</b>	<b>'W' option</b>	<b>Contact us</b>

**SPECIFICATION**

**CABLE ASSEMBLY**

**ELECTRICAL CHARACTERISTICS**

Stripping	a	b	c	d	e	f
mm	1.30	0.00	0.00	0.00	0.00	0.00

Impedance		<b>50</b> Ω
Frequency		<b>0-26.5</b> GHz
VSWR	<b>1.35</b> +	<b>0.000</b> x F(GHz) Maxi
Insertion loss		<b>0.12</b> √F(GHz) dB Maxi
RF leakage	- (	* - F(GHz)) dB mini
Voltage rating		<b>335</b> Veff Maxi
Dielectric withstanding voltage		<b>500</b> Veff mini
Insulation resistance		<b>5000</b> MΩ mini

Assembly instruction :

Recommended cable(s)  
KS 1  
RG 405

Cable retention

- pull off **200** N mini
- torque **NA** N.cm

**MECHANICAL CHARACTERISTICS**

**TOOLING**

Center contact retention		
Axial force – Mating end	<b>6.7</b>	N mini
Axial force – Opposite end	<b>6.7</b>	N mini
Torque	<b>NA</b>	N.cm mini
Recommended torque		
Mating	<b>NA</b>	N.cm
Panel nut	<b>NA</b>	N.cm
Clamp nut	<b>NA</b>	N.cm
A/F clamp nut	<b>0.000</b>	mm

Part Number	Description	Hexagon
.	.	.
R282.740.030	SOLDERING MOUNTING	
R282.743.120	POSITIONER FOR SOLDERING SMP	
R282.051.000	STRIPPING TOOL	
R282.062.010	POINTER GAUGE	

Mating life	<b>100</b>	Cycles mini
Weight	<b>0.453</b>	g

**OTHERS CHARACTERISTICS**

\*RF leakage:-80dB DC-3GHz  
-65dB: 3-26.5GHz  
Compliant with MIL.STD.348

**ENVIRONMENTAL**

Operating temperature	<b>-65/+165</b>	° C
Hermetic seal	<b>NA</b>	Atm.cm3/s
Panel leakage	<b>NA</b>	

Issue : 0606 C

In the effort to improve our products, we reserve the right to make changes judged to be necessary.



**FEMALE RIGHT ANGLE PLUG SOLDER TYPE**

**R222.152.000**

**CABLE .085**

Series : SMP

**COMPONENT**

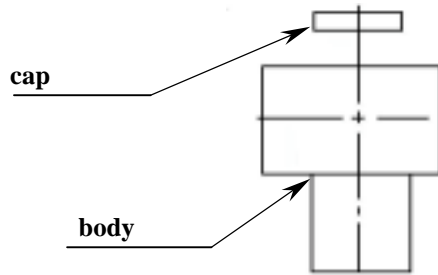

**STRIPPING CABLES**

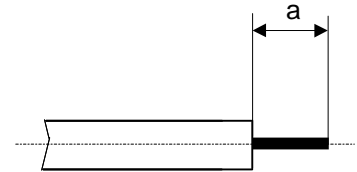

We recommend a thermal preconditioning cable

**1**

Strip the cable .  
Clean the cable .  
The iron temperature shall not exceed 250°C max

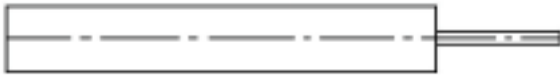

**2**

Slide the assembly in the the soldering jig and tighten.  
Slide cable into connector until it bottoms against the body and tighten.  
Solder the body onto the cable .

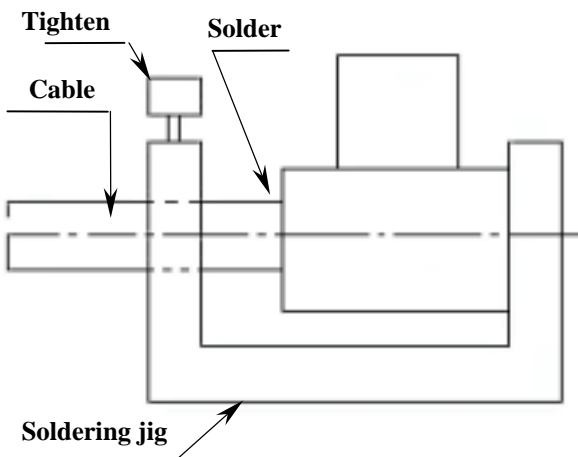

**3**

After cooling remove the cable assembly from the jig .  
Slide the body into the positioner until its bottoms against the positioner  
Slide cable assembly onto the jig .  
Tighten and solder the contact.  
After cooling remove cable assembly from the jig.

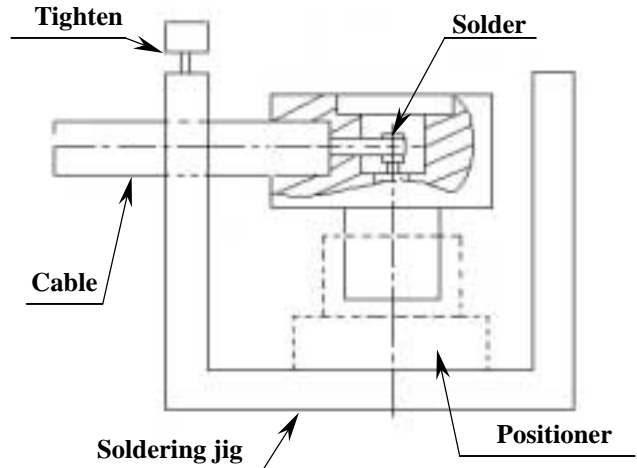

**4**

Place cable assembly into a dia D = 3.8 +-0.1 and thickness E = 4 +-0.1 .  
Place cable assembly above a flat pressing tool .  
To fit the cap until it bottoms against the body .  
(direction F)

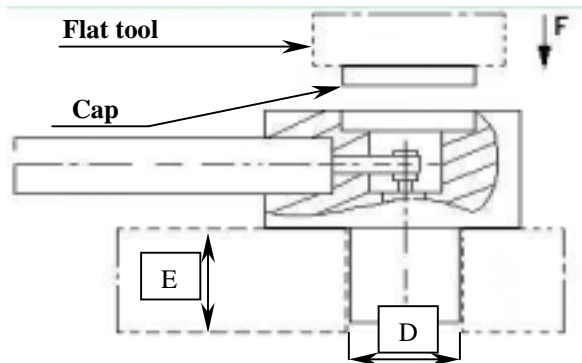

Issue : 0606 C

In the effort to improve our products, we reserve the right to make changes judged to be necessary.

